

## Technology description

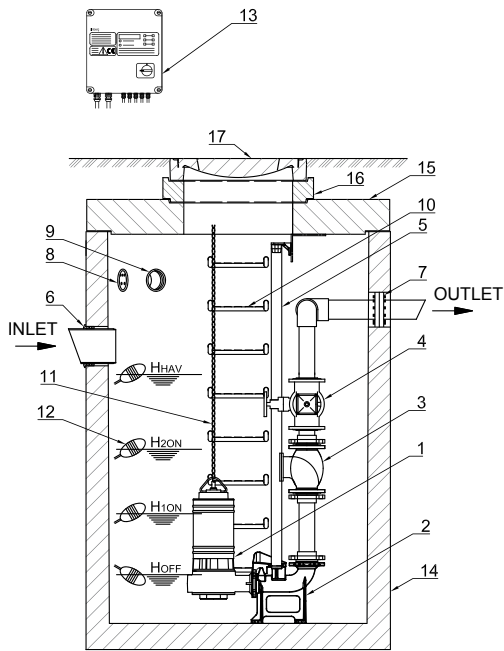

1. Pumps
2. Bottom cupling
3. Ball non-return valve
4. Ball valve
5. Stainless steel guide rod
6. Connector seal, Inlet pipe
7. Connector seal, discharge pipe
8. Cable gland
9. Connector seal, Ventilation seal
10. Steps
11. Stainless steel chain
12. Floating switch
13. Control panel
14. Concrete tank
15. Cover plate
16. Shaft ring
17. Roadworthy access cover

HHAV – alarm signalization  
 H2ON – start pump 2, both pumps are in operation  
 H1ON – start pump 1  
 HOFF – minimal water level, stop pumping

