

Technology description

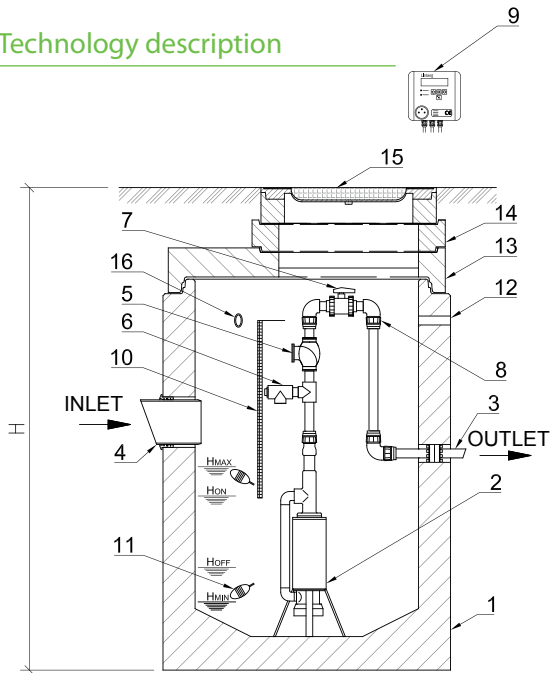

1. Concrete tank
2. Pump with grinder system
3. Discharge pipe
4. Inlet – gravity
5. Ball non-return valve
6. Safety valve
7. Ball valve
8. Screw connection
9. Control panel
10. Level sensing electrode
11. Float switch
12. Opening for cable
13. Cover plate
14. Shaft ring
15. Roadworthy access cover
16. Ventilation

HMAX – maximal water level, alarm

HON – pump ON

HOFF – pump OFF

HMIN – minimal water level, service